

QUESTIONARIO

Questionario coperture a rullo

Roll-up covers question form

Posizione di lavoro sulla macchina Work position on the machine

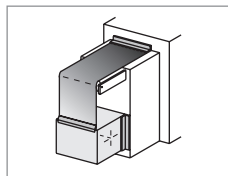
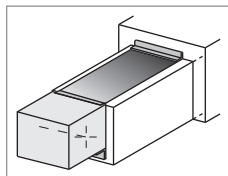
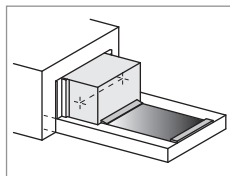
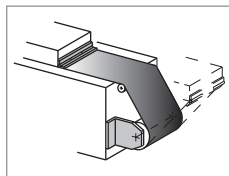

Orizzontale
Horizontal

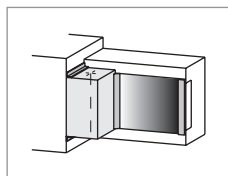
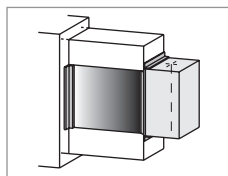
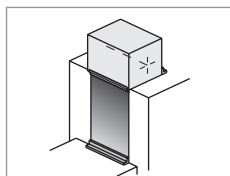
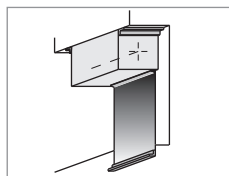

Verticale
Vertical

Frontale
Frontal

Tipo di macchina (ad esempio rettifica):

Type of machine (e.g. grinding machine):

Condizioni Conditions

Ambiente Environment

Polvere
dust

altro:
other:

Temperatura ambiente

Ambient temperature _____ °C

Temperatura del materiale

Material temperature _____ °C

Refrigerante:

Coolant:

si
yes

no
no

QUESTION FORMS

Lunghezza del tappeto esteso A_Z : _____ mm
 Length of the roller band extended A_Z : _____ mm

Larghezza della copertura a rullo B: _____ mm
 Width of roll-up cover B: _____ mm

Corsa L_S : _____ mm
 Travel length/Stroke L_S : _____ mm

Velocità V: _____ m/min
 Travel speed V: _____ m/min

Accelerazione a: _____ m/s^2
 Acceleration a: _____ m/s^2

Ingombro del tappeto avvolto (L x l): _____ mm
 Installation space wound up roll-up cover (L x W): _____ mm

Esecuzioni Versions



H_1 sull'angolare di fissaggio è in funzione della lunghezza del tappeto, dello spessore e del diametro di avvolgimento.
 H_1 on fixing angle depends on the band length, the band thickness and thereby the winding diameter.

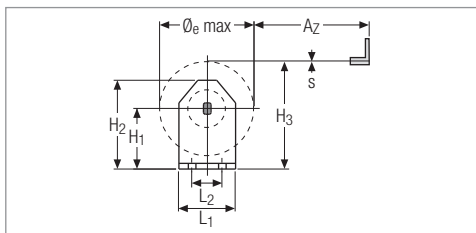
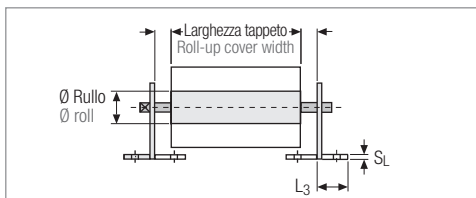

Copertura a rullo senza cassonetto (Esecuzione del tappeto in materiale plastico)
 Roll-up cover without housing (version with plastic band)

Informazioni supplementari Supplementary information

Grid area for supplementary information.

QUESTIONARIO

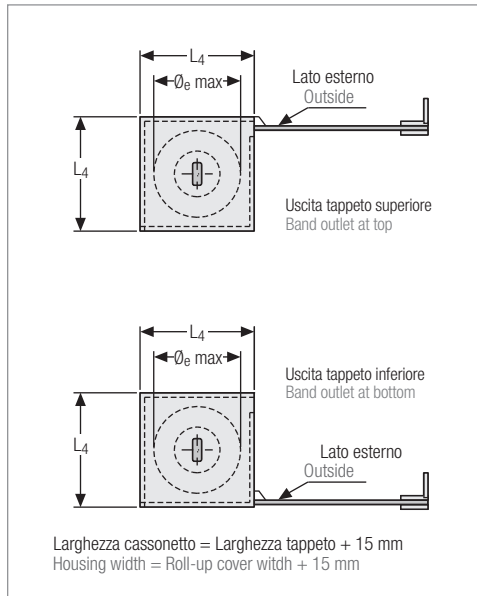
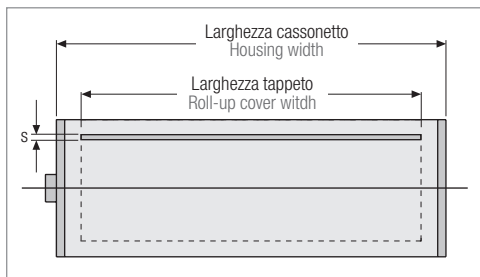

Copertura a rullo con cassonetto (versione tappeto in materiale plastico o acciaio)
Roll-up cover with housing (version with plastic or steel belt)

Uscita tappeto superiore
Band outlet at top

Uscita tappeto inferiore
Bottom band outlet

Materiali Materials

Esecuzione del tappeto in materiale plastico (la scelta del materiale avviene in base al caso applicativo, esempio in PVC, PUR, Kevlar®)
Plastic belt design version (material selection according to application e.g. PVC, PUR, Kevlar®)

Tappeto in acciaio:
Steel band design version:

INOX 0,2 mm INOX 0,3 mm INOX 0,4 mm

INOX 0.2 mm INOX 0.3 mm INOX 0.4 mm

Fissaggio tappeto sulla macchina Belt fixing on machine

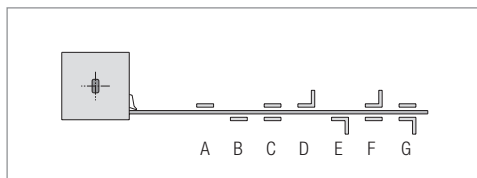
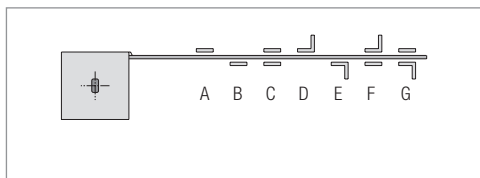

Esecuzione del fissaggio (esempio 1D):

Band fixing version (e.g. 1D):

QUESTION FORMS

Fissaggio del cassonetto Fixing connection of the housing

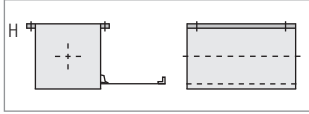
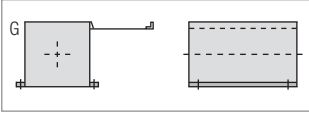
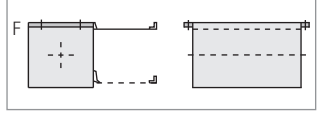
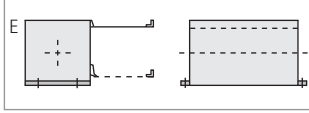
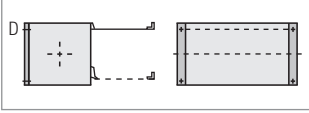
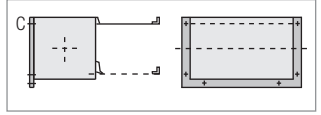
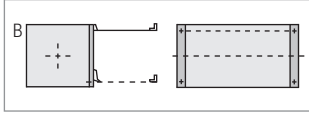
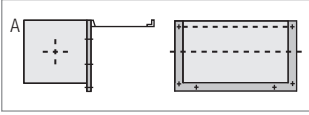

Fissaggio del cassonetto (ad esempio C):
Design version for housing fixing (e.g. C):

Schizzo/immagini allegate:
Sketch/Pictures enclosed:

 si
yes

 no
no

Informazioni supplementari Supplementary information

Grid area for supplementary information.