

KABELSCHLEPP

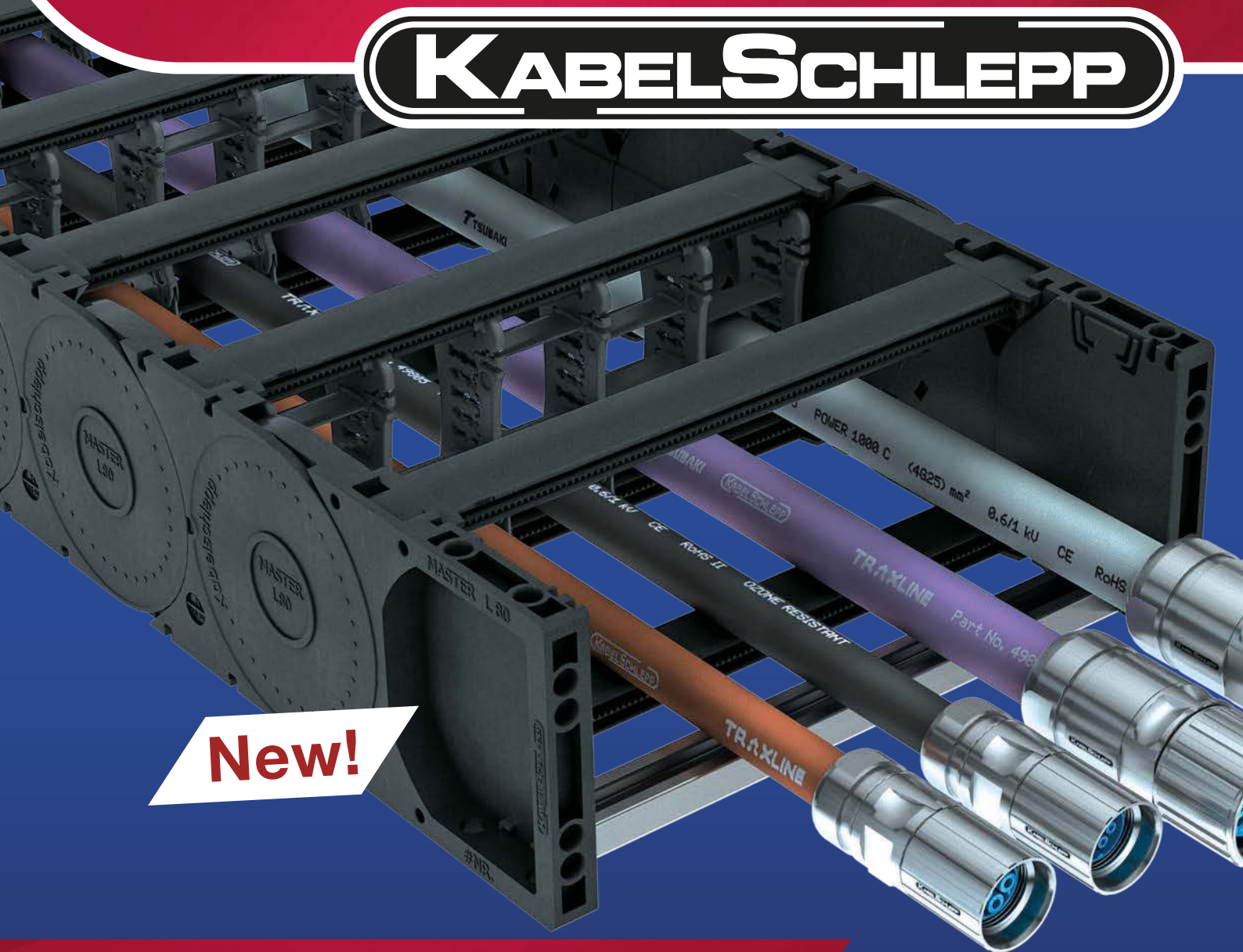

New!

MASTER LE60/LE80 with new divider system TS3

Order in the smallest spaces

PERFECT ORDER IN THE SMALLEST SPACES

The requirements for cable carriers, with regard to the decreasing packaging space in machines on the one hand and the demand for more internal space with regard to Industry 4.0 on the other hand, are becoming ever more complex. Furthermore, the cables vary greatly in function, cross section and sheathing material.

To meet these heterogeneous demands, TSUBAKI KABELSCHLEPP has developed the new **MASTER LE60/LE80** together with a new **divider system TS3**. The result: more space on the inside through environmentally conscious reduction of materials, with increased strength and full

flexibility for cable separation. It is just as clever, versatile and variable as the tasks for which it was designed. This allows you to easily keep the necessary overview for maintenance and changes.

With the right dividers, you can achieve the best possible result regarding space requirements, systematics and easy maintenance. Various combination options allow you to find the perfect configuration. As all components can be changed and supplemented later on, your cable carrier remains open to adapt to new tasks.



TOTALTRAX® complete systems

Benefit from the advantages of a TOTALTRAX® complete system. Complete delivery from a single source – with a guarantee certificate on request! Learn more at kabelschlepp.de/totaltrax



UMB connector with strain relief comb



UMB connector with C-rail and LineFix® strain relief



TRAXLINE® cables for cable carrier



Replaceable glide shoes made of plastic

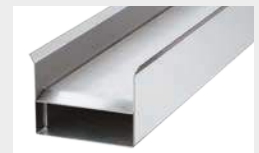

Guide cannels for long travel lengths

More informationen:

Fon +49 (0)2762 4003-0 or Online: kabelschlepp.de/master

Subject to change

MASTER LE60/LE80

Quiet and weight-optimized cable carrier with new divider system TS3



Inner heights
60 – 80 mm



Inner widths
85 – 250 mm



Pitch
91 – 111 mm



Additional load
up to 25 kg/m



Travel length unsupported
up to 7.9 m



Travel length gliding
up to 80 m



Travel speed
up to 10 m/s



Acceleration
up to 50 m/s²



Features

- Solid plastic cable carrier with many possibilities for internal subdivision
- New stay variant RE
- Divider system TS0 for vertical separation
- Divider system with TS1 continuous height separation
- Divider system TS3 with height separation made of plastic section subdivisions
- 8 widths available
- Save costs through easy installation
- Save time through fast cable laying
- For cables with large diameters
- Good ratio of inner to outer dimensions
- Low intrinsic weight
- Optionally with C-rail integrated in the end connector

Type	h_i [mm]		B_i [mm]								t [mm]		KR [mm]								Stay variant
	60	80	85	125	138	150	180	196	225	250	91	111	135	150	200	250	300	350	400	500	RE
MASTER LE60	60	85	125	138	150	180	196	225	250	91	135	150	200	250	300	350	400	500		■	
MASTER LE80	80	85	125	138	150	180	196	225	250	111	–	150	200	250	300	350	400	500		■	

More informationen:

Fon +49 (0)2762 4003-0 or Online: kabelschlepp.de/master

Subject to change

The new divider system TS3

Space saving, versatile inner distribution with very fast opening

- Fast, time saving harnessing
- Easy to open and fill from all sides
- 50 % less packaging space required when using the new TS3 dividers compared to the predecessor
- 37.5 % less space required when using the new TS3 section subdivisions compared to previous section subdivisions
- End divider for using the full inner width
- Secure seating of the height separators through locking divider
- Height separators for inner distribution can be inserted through 5 levels and are available in 33 different lengths
- Particularly space saving height separation (2.5 mm) with wide contact surface and rounded edges
- Complete divider system can be moved and fixed in the cross section

- Movable dividers within the chambers possible
- Fixed chamber width from 14 to 112 mm
- 2.5 mm divider grid
- Also available as a closed cable carrier with plastic or aluminum cover

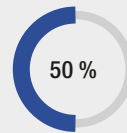

50 % vertical space saved compared to the predecessor

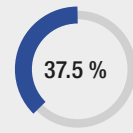

37.5 % horizontal space saved compared to the predecessor

Where a variety of cables are used, you need:

- Individual organizing systems
- Low friction design
- Easy assembly
- Subsequent adaptation options

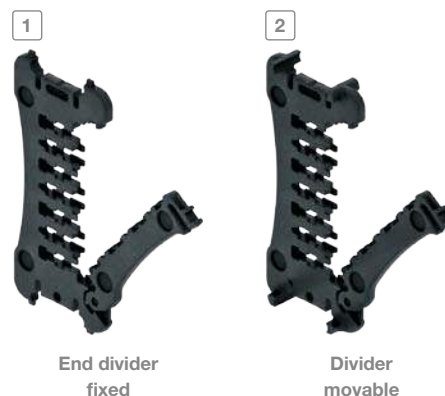
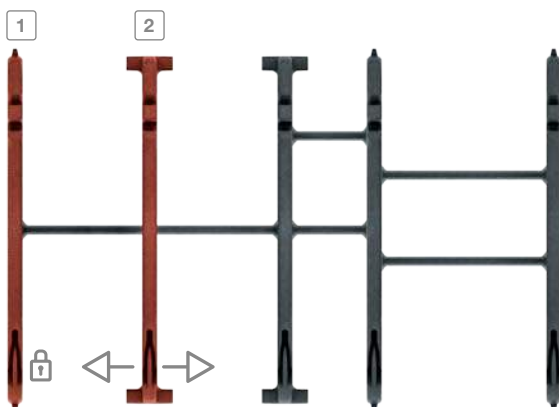

The new divider system TS3

Width optimized and ready for Industry 4.0

Width comparison

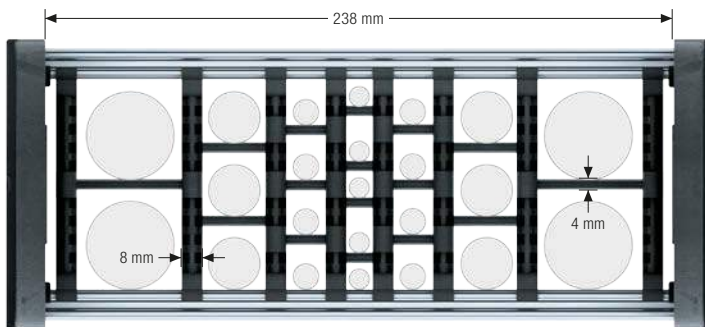

Previous divider system TS3 with stay variant RE

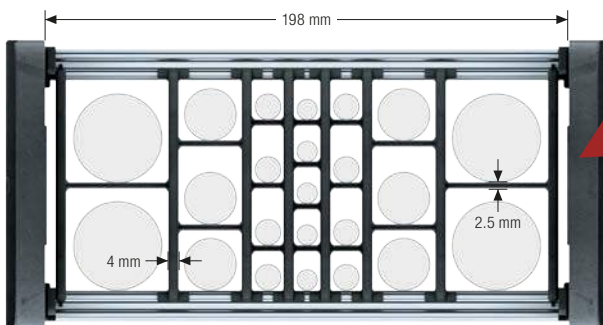

Clear space saving with same filling capacity through the new divider system TS3 with stay variant RE

Width optimization through adapted dividers

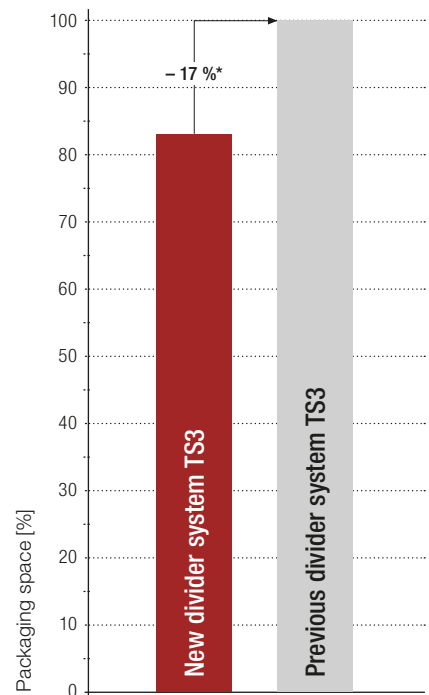

*For inner width $B_i = 238$ mm with stay variant RE

Easy-to-assemble cable separation on the smallest footprint



1
Insert cables, fold open dividers and insert first height separator

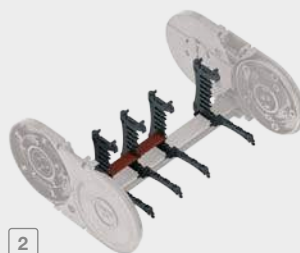

2
Insert additional cables, insert height separators



3
Insert cables, complete height separators

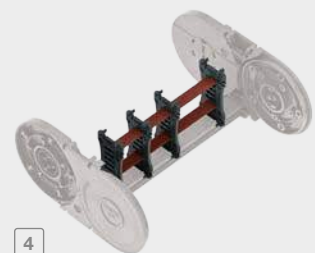

4
Fold down dividers

More informationen:

Fon +49 (0)2762 4003-0 or Online: kabelschlepp.de/master

Subject to change

KABELSCHLEPP

CABLE CARRIER SYSTEMS

Cable carriers made of steel and plastic
QUANTUM® cable and hose carrier system
PROTUM® cable and hose carrier system
ROBOTRAX® cable and hose carrier system

TRAXLINE® – CABLES FOR MOTION

Continuous bending hi-flex cables for cable carriers
TOTALTRAX® complete turn-key carrier systems
Pre-assembled cables

GUIDEWAY PROTECTION SYSTEMS

Telescopic covers
Link apron covers
Way wipers
Conical spring covers
Bellows
Protective devices

CONVEYOR SYSTEMS

Hinged belt conveyors
Scraper conveyors
Belt conveyors

**All products
in one app.**
Available for iOS
and Android.

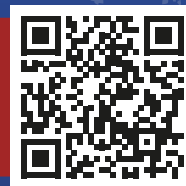

TSUBAKI KABELSCHLEPP GmbH

Daimlerstraße 2
D-57482 Wenden-Gerlingen
Fon: +49 2762 4003-0
Fax: +49 2762 4003-220
E-mail: info@kabelschlepp.de
kabelschlepp.de

TSUBAKI KABELSCHLEPP worldwide

For contacts, addresses and further
information visit our website
kabelschlepp.de